

PHOTOCOPIABLE SHEET 1.1
CHRISTENING CHECKLIST
(to use with 'Christening call', p. 52)

CHRISTENING CHECKLIST

Choose godparents

Contact the church

Book a hall for the party

Invite friends and family

Go to preparation sessions

Sort out clothes for everyone

Ask someone to take photos

Order a cake

Go to church before the big day

PHOTOCOPIABLE SHEET 1.2
 (To use with 'Why are we here?' p. 54)

**HOW MUCH DID EACH OF THE FOLLOWING
 INFLUENCE YOUR DECISION TO HAVE YOUR CHILD
 BAPTIZED AT A CHRISTENING?**

	A lot	A little	Not at all
Family tradition			
Encouragement from family			
Thanksgiving for the birth of your child			
Wanting godparents for your child			
Wanting your child to belong in the church			
To help protect your child in life			
Wanting a good start for your child			
To make sure your child has a place in heaven			
To have a party, celebrating with family and friends			
To mark the start of a journey of faith for your child			
To have a blessing for your child			
To help your child choose to be a Christian in future			
To do the same thing as my friends are doing			
To support what my partner wants to happen			

PHOTOCOPIABLE SHEET 1.3
PRAYER CARD
(see p. 61)

Loving God,
we pray for your blessing on our family
as we prepare for the christening of our child.
Help us to follow Jesus together.
Amen.

Creator God,
We thank you for the gift of the life of this child
who is to be baptized.
May your blessing of peace and joy be with them
and protect them all of their days.
We make this prayer in the name of your Son, Jesus.
Amen.

PHOTOCOPIABLE SHEET 1.4

'MY LIFE'

(to use with 'Important people in my life', p. 64)

MY LIFE	
BIRTH	
MAJOR EVENTS (3-5 in each time period)	IMPORTANT PEOPLE
0-10 years	
.....
.....
.....
.....
.....
10-20 years	
.....
.....
.....
.....
.....
20 years - now	
.....
.....
.....
.....
.....
PRESENT DAY	

PHOTOCOPIABLE SHEET 2.1
TOPICS COVERED IN SESSION 1
(to use with 'Welcome and introductions', p. 81)

Christening and baptism.

Choosing names.

Getting ready for a baby.

Getting ready for a christening.

Who are godparents?

Why these godparents?

Prayer.

Oil, water, light.

PHOTOCOPIABLE SHEET 2.2
EXPERIENCE AND EXPECTATIONS GAME
Instructions (see p. 82)

EXPERIENCE AND EXPECTATIONS GAME

INSTRUCTIONS FOR ROLLING THE DICE

If you roll a ...	Name one thing that ...
1	... you like about church.
2	... you think churches could do better.
3	... you remember about the first time you went to church.
4	... you remember about the last time you visited a church.
5	... you are hoping for at your child's christening.
6	... you are worried about for your child's christening.

PHOTOCOPIABLE SHEET 2.3
TREASURE MAP
(to see with activity on p. 84)

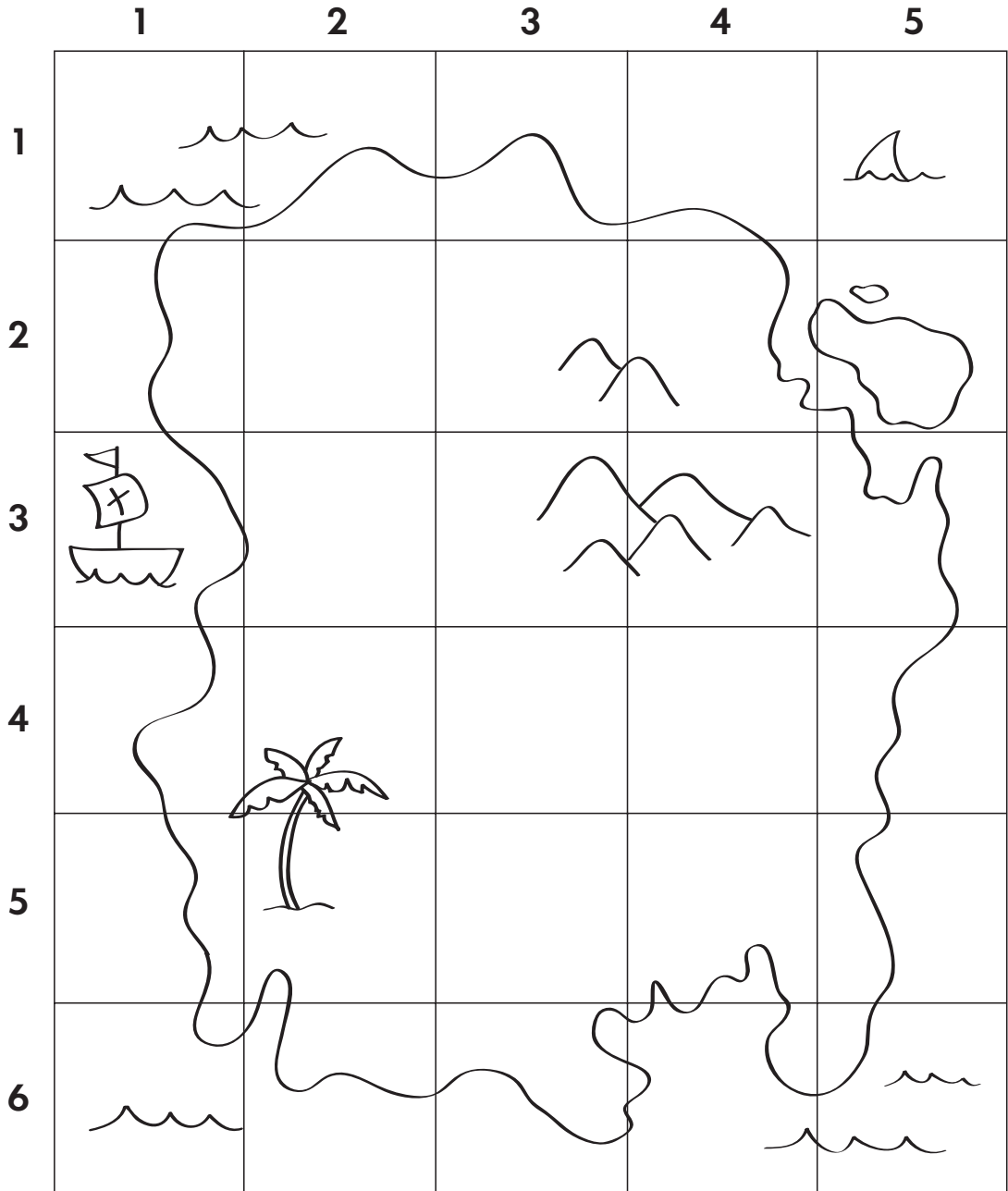

PHOTOCOPIABLE SHEET 2.4
PROMISES CARD
(see p. 91)

Dear (*child's name*),

I promise that I will

With love from

PHOTOCOPIABLE SHEET 3.1
TOPICS COVERED IN SESSION 2
(to use with 'Welcome and introductions', p. 110)

Expectations of church

What church is like

The Bible

The service

Friends and family

Oil

Water

Candle

Gifts

Promises

Prayer

What we do in the service

What we say in the service

PHOTOCOPIABLE SHEET 3.2
 THE UPS AND DOWNS OF FAMILY LIFE
 Board game and cards (see p. 111)

	YOUR CHILD IS 18!
SECONDARY SCHOOL	
PRIMARY SCHOOL	
EARLY YEARS	
	BIRTH <i>START HERE</i>

EARLY YEARS (1)

<p>Your baby smiles for the first time.</p> <p><i>Move forward 2 squares</i></p>	<p>While changing your baby's nappy, he/she is sick all over you.</p> <p><i>Move back 1 square</i></p>
<p>Your baby sits without support.</p> <p><i>Move forward 1 square</i></p>	<p>Your child takes his/her first step.</p> <p><i>Move forward 2 squares</i></p>
<p>Your child can crawl! Take time out to find the stair gates.</p> <p><i>Miss 1 turn</i></p>	<p>It's your child's christening day.</p> <p><i>Move forward 2 squares</i></p>
<p>Teething is making your child restless. You haven't slept for two nights.</p> <p><i>Go back one square</i></p>	<p>There's an artist in the family – and he/she has used lipstick to decorate the bathroom walls.</p> <p><i>Miss 1 turn while you clean up</i></p>

EARLY YEARS (2)

<p>Your child says his/her first word.</p> <p><i>Move forward 1 square</i></p>	<p>When you clap your hands, your child claps back.</p> <p><i>Move forward 1 square</i></p>
<p>Your child jumps up and down, both feet off the ground.</p> <p><i>Move forward 1 square</i></p>	<p>Your child points at something and says, 'Look!'</p> <p><i>Move forward 1 square</i></p>
<p>Your child no longer needs nappies.</p> <p><i>Move forward 2 squares</i></p>	<p>Your child no longer needs nappies.</p> <p><i>Move forward 1 square</i></p>
<p>Your child waves when you say goodbye.</p> <p><i>Move forward 1 square</i></p>	<p>Your child gives you a big hug.</p> <p><i>Move forward 1 square</i></p>

PRIMARY SCHOOL (1)

<p>It's the first day of school!</p> <p><i>Move forward 2 squares</i></p>	<p>You have a friend of your child round to play and everything goes well.</p> <p><i>Move forward 1 square</i></p>
<p>You have a friend round to play, but your child tells you to send them home.</p> <p><i>Move back 1 square</i></p>	<p>You go out for a meal and everyone sits and eats and chats nicely for the whole time.</p> <p><i>Move forward 1 square</i></p>
<p>Your child brings in a flower and tells you to look carefully – 'Look at all the patterns.'</p> <p><i>Move forward 1 square</i></p>	<p>You are out in the evening and your child asks why the stars shine.</p> <p><i>Move forward 2 squares</i></p>
<p>Your child yells, 'I hate you!'</p> <p><i>Move back 1 square</i></p>	<p>Your child gives you a big hug.</p> <p><i>Move forward 2 squares</i></p>

PRIMARY SCHOOL (2)

<p>There are nits in the classroom. It takes ages to check your child.</p> <p><i>Miss 1 turn</i></p>	<p>The stomach bug that's been going round school comes home.</p> <p><i>Miss 1 turn</i></p>
<p>Your child's teacher phones to tell you he/she is not happy at school and asks whether there are any problems at home.</p> <p><i>Go back 1 square</i></p>	<p>Your child writes his/her first story.</p> <p><i>Go forward 1 square</i></p>
<p>You struggle with your child's maths homework.</p> <p><i>Miss 1 turn while you work it out</i></p>	<p>You have a wonderful sunny day together at the seaside.</p> <p><i>Move forward 1 square</i></p>
<p>One of your child's godparents takes him/her out for the day.</p> <p><i>Move forward 1 square</i></p>	<p>Your child falls off a swing and breaks an arm.</p> <p><i>Go back one square</i></p>

SECONDARY SCHOOL (1)

<p>It's the first day of secondary school.</p> <p><i>Move forward 2 squares</i></p>	<p>It's your child's last day at school.</p> <p><i>Move forward 2 squares</i></p>
<p>Your child has a boyfriend/girlfriend.</p> <p><i>Miss 1 turn while you work out how you feel about this</i></p>	<p>At parents' evening, you are told that your child is always polite and helpful.</p> <p><i>Move forward 1 square</i></p>
<p>Your child does better than you were hoping in his/her exams.</p> <p><i>Move forward 1 square</i></p>	<p>Your child has shut themselves in their bedroom and says they never want to speak to you again.</p> <p><i>Move back 1 square</i></p>
<p>Your child gives you a big hug.</p> <p><i>Move forward 2 squares</i></p>	<p>The school phones to tell you they are worried about your child. Friends say your child may be self-harming.</p> <p><i>Move back 2 squares</i></p>

SECONDARY SCHOOL (2)

<p>It's pay day! Your child brings home their first earnings.</p> <p><i>Move forward 1 square</i></p>	<p>Your child puts his/her clothes away without being reminded.</p> <p><i>Move forward 1 square</i></p>
<p>Your child makes his/her own sandwiches for school.</p> <p><i>Move forward 1 square</i></p>	<p>Dinner time – and your child has cooked it!</p> <p><i>Move forward 1 square</i></p>
<p>You have a lovely day together at the seaside.</p> <p><i>Move forward 1 square</i></p>	<p>You go out for a meal together without anyone complaining or using a phone at the table.</p> <p><i>Move forward 1 square</i></p>
<p>Your find a pile of dishes in your child's room – and they are growing many colours of mould.</p> <p><i>Move back 1 square</i></p>	<p>Your child loses his/her shoes – again.</p> <p><i>Miss a turn while you look for them</i></p>

PHOTOCOPIABLE SHEET 3.3
BIBLE STORIES LIST
(to use with 'Sharing God's story', p. 115)

LIST OF BIBLE STORIES

Adam and Eve in the Garden of Eden

Noah's ark

Moses leads the people of Israel through the Red Sea

David and Goliath

Jonah and the whale

Daniel in the lions' den

Jesus is born

The Good Samaritan

Jesus heals a man lowered through the roof

Jesus meets Zacchaeus

Jesus meets the woman at the well

Jesus goes to the home of Mary and Martha

Jesus dies on the cross

The women find Jesus' tomb is empty

The Holy Spirit comes

St Paul meets Christ on the road to Damascus

PHOTOCOPIABLE SHEET 3.4
TEMPLATE FOR PRAYER CUBE
(to be used with 'Make a prayer cube or chatterbox', p.121)

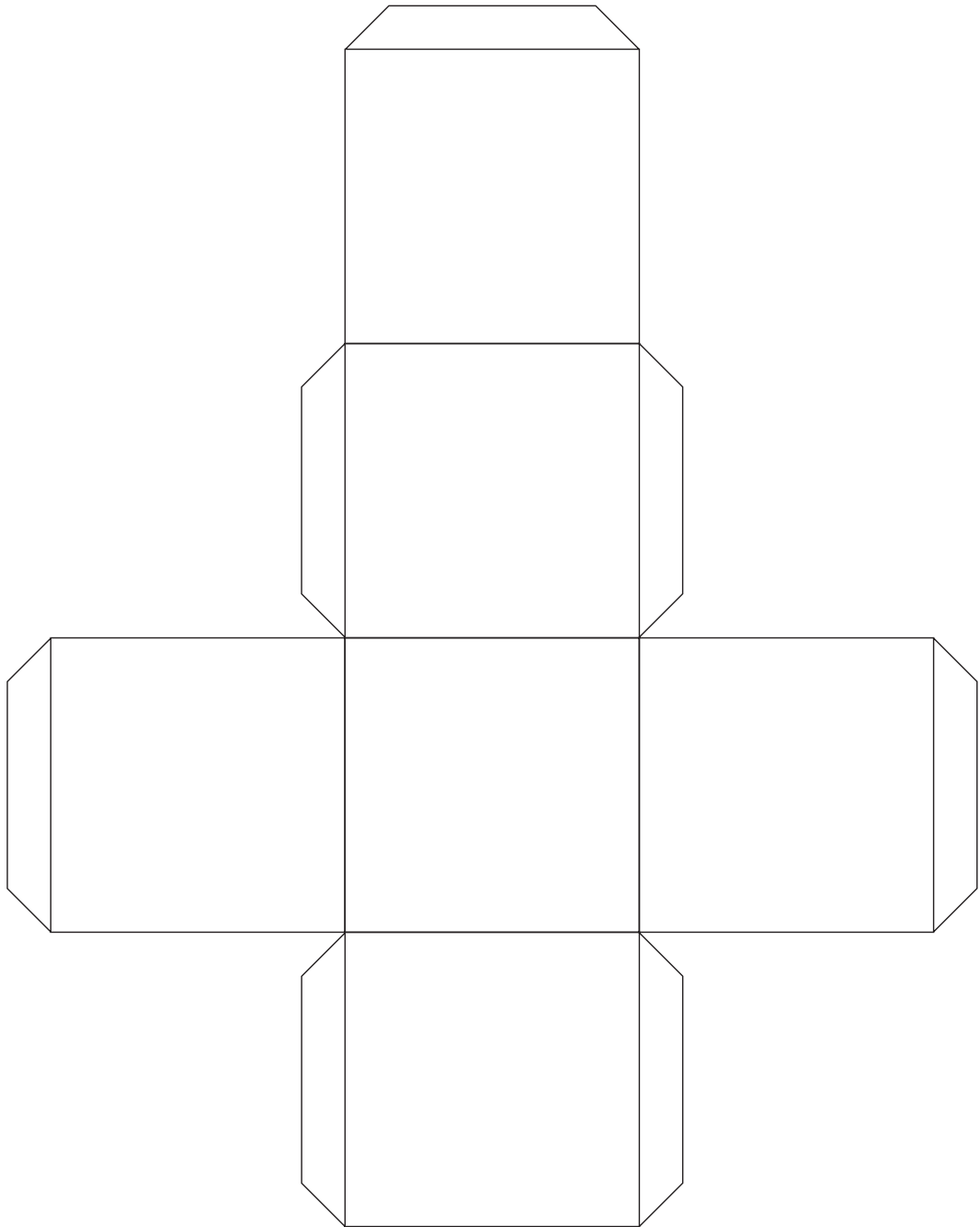

PHOTOCOPIABLE SHEET 3.5
TEMPLATE FOR A CHATTERBOX

(to be used with 'Make a prayer cube or chatterbox', p.121)

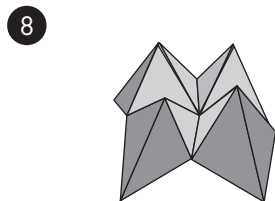
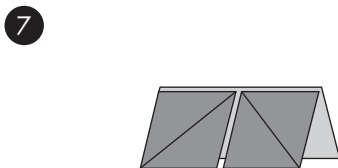
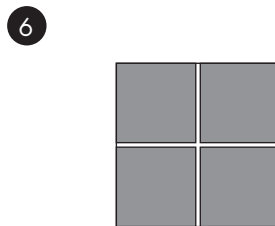
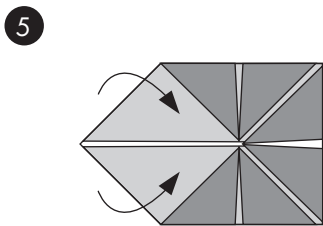
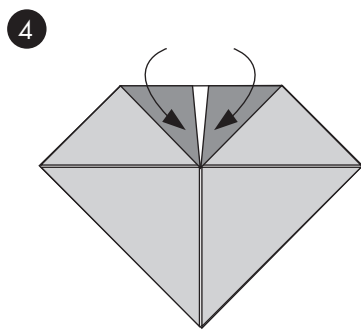
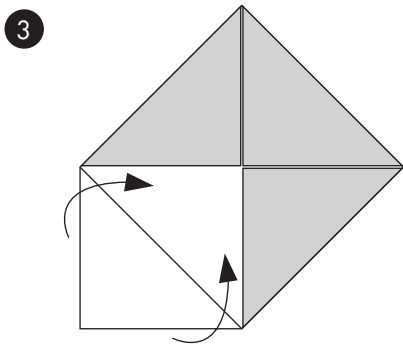
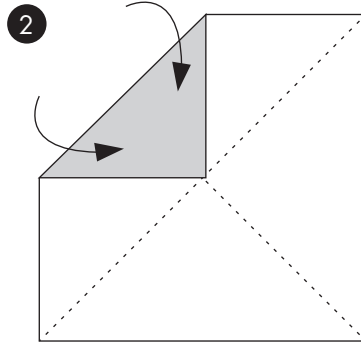
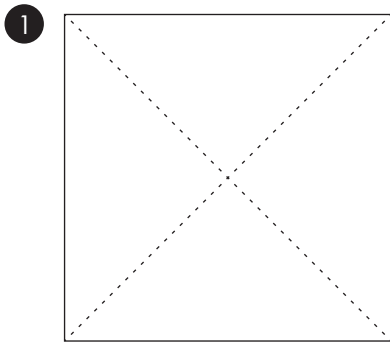

PHOTOCOPIABLE SHEET 3.6
PRAYER CARD
(see p.122)

Loving God,

I pray for

(space for child's name)

Surround them with love and help them know more about
your love for them every day.

Amen.